

## REFRIGERATOR FEATURES AND SPECIFICATIONS

### ORIGINAL SIZE- 20.9 cubic feet

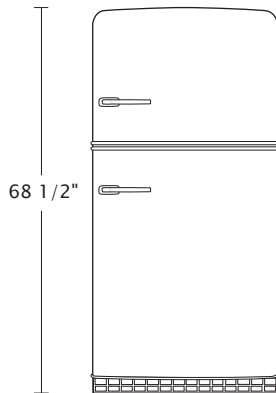

### STUDIO SERIES- 14.4 cubic feet

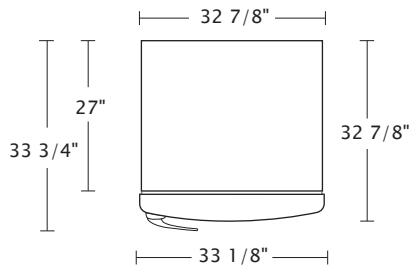
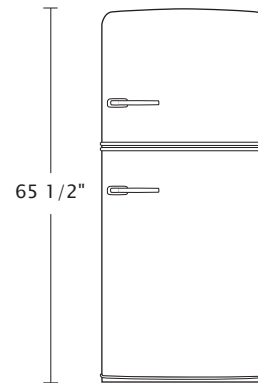
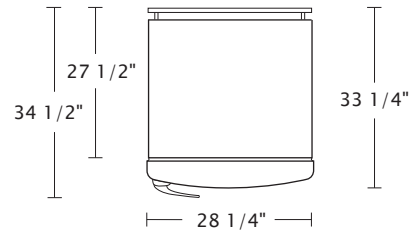

Total Capacity	20.9 cu. ft.
Refrigerator Capacity	14.5 cu. ft.
Freezer Capacity	6.4 cu. ft.
Cabinet Width	32 7/8 in.
Door Width	33 1/8 in.
Overall Depth (coil free back)	33 3/4 in.
Depth (minus handles)	32 7/8 in.
Depth (cabinet only)	27 in.
Height	68 1/2 in.
Clearance: Back	1/2 in.
Clearance: Side	1/4 in.
Side Clearance for door to open 90°	4 1/2 in.
Adjustable Rollers	Standard
Energy Guide (kWh/year)	413 (Energy Star Rated)
Power Rating	115V, 15A, 60Hz

**FEATURES:**

Stamped Metal Body, Authentic Chrome Trim, 2 Half-Width Clear Crisper Pans, Temperature Management System, 1 Adjustable Full-Width Freezer Shelf, 3 Easy-Clean Spill-Proof Glass Shelves, Energy Star Available, Optional Interior Ice Maker, Available Left Hand Hinge, 1 Year Warranty on Parts and Labor, 5 Year Warranty on the Compressor

Total Capacity	14.4 cu. ft.
Refrigerator Capacity	10.6 cu. ft.
Freezer Capacity	3.8 cu. ft.
Cabinet Width	28 1/4 in.
Door Width	28 1/4 in.
Overall Depth (including coils)	34 1/2 in.
Depth (minus handles)	33 1/4 in.
Depth (cabinet and coils only)	27 1/2 in.
Height	65 1/2 in.
Clearance: Back	1/2 in.
Clearance: Side	1/4 in.
Side Clearance for door to open 90°	4 1/2 in.
Adjustable Rollers	Standard
Energy Guide (kWh/year)	438
Power Rating	115V, 15A, 60H

**FEATURES:**

Stamped Metal Body, Authentic Chrome Trim, Full-Width Crisper, Available Left Hand Hinge, Temperature Management System, Optional Interior Ice Maker, 1 Year Warranty on Parts and Labor, 5 Year Compressor Warranty



## FEATURES AND SPECIFICATIONS

### DISHWASHER

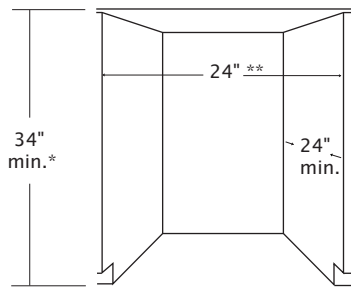
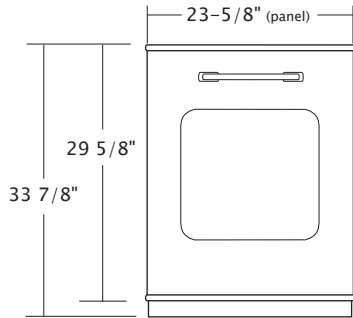

### UNDER COUNTER REFRIGERATOR

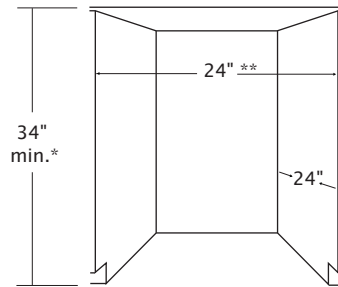
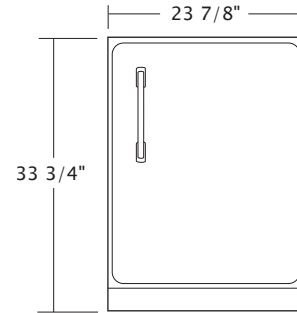

Capacity	14 Place Settings
Number of Cycles	4
Cycles	Heavy Duty, Normal, Light/ China, Rinse Only
Cycle Options	6
Sound Reduction System	Whisper Quiet® Plus (52 dBA)
Energy Guide (kWh/year)	334 (Energy Star Qualified)
Warranty	One Year Parts and Labor
Electrical	15 OR 20 Ampere, 120 Volts, 60 Hertz (1/second). AC-ONLY. Use copper wire only. Grounded circuit is REQUIRED. A time-delay fuse or circuit breaker and separate circuit is recommended.

**FEATURES:**

Stamped Metal Body, Authentic chrome trim,  
Commercial Grade Stainless Steel Interior, Energy Star Qualified

\* Measured from the lowest point on the underside of countertop.

\*\* Minimum, measured from narrowest point of opening

Total Capacity	6.1 cubic feet
Height	33-3/4"
Width	23-7/8"
Depth	25" (26-1/2" inc. handle)
Weight	120lbs
Energy Guide (kWh/year)	301 (Energy Star Qualified)
Warranty	One Year Parts and Labor, 5 Years on Compressor

**FEATURES:**

Stamped Metal Body, Temperature Management System, Energy Star,  
Optional Interior Freezer (Refrigerator 5.3 cu. ft., freezer 0.73 cu. ft.),  
Available Left Hand Hinge, Interior Shelving in both the door and cabinet,  
Includes door ajar alarm, Amber LED temperature display

\* Measured from the lowest point on the underside of countertop.

\*\* Minimum, measured from narrowest point of opening.

## RANGE FEATURES AND SPECIFICATIONS

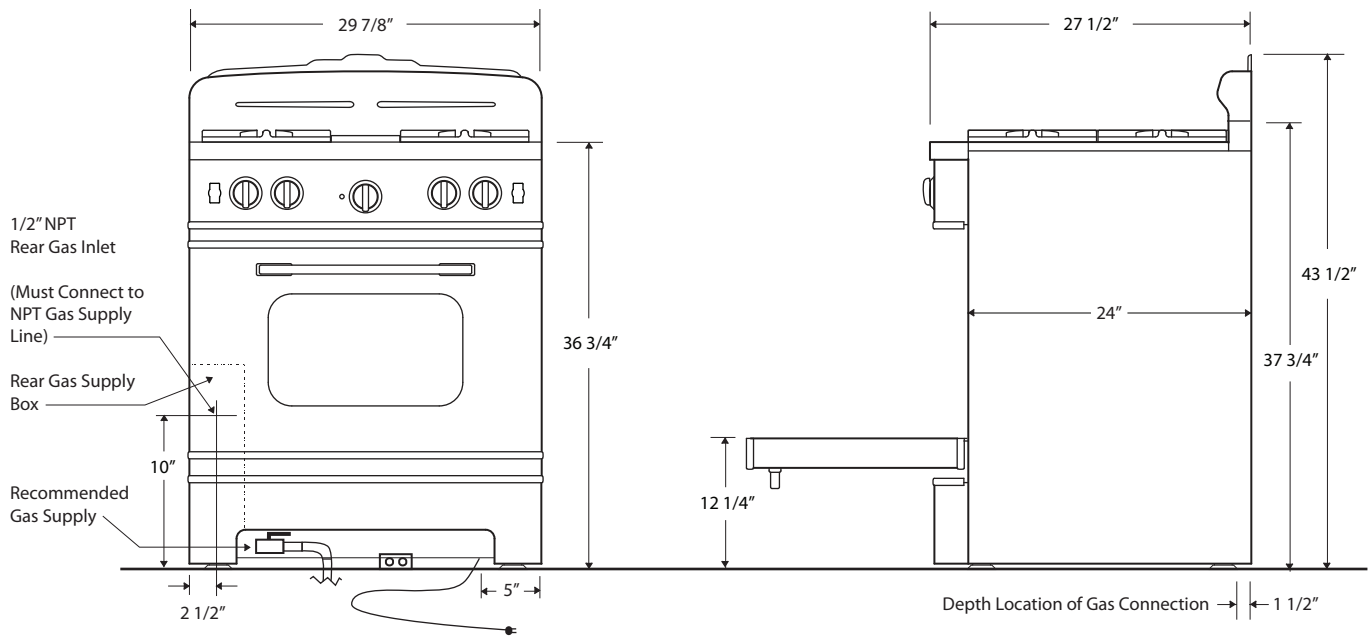

Front Burners	15,000 BTU	*Easy to clean Sealed Burner Top
Back Left Burner (Simmer)	6,000 BTU	*Automatic electronic ignition and re-ignition system
Back Right Burner	10,000 BTU	*24" depth for compatibility with standard kitchen cabinetry
Infrared Broiler Rating	15,000 BTU	*Convection fan
Oven Burner Rating	30,000 BTU	*Full Extension oven rack
Electrical Requirements	120 VAC, 15 Amps,	*Heavy-duty, commercial stainless steel construction
*(Unit must be on a non-GFI, dedicated outlet)	Single Phase	*1 year parts and labor warranty
Operating Gas Pressure	NAT: 5.0" WC LP: 10.0" WC	<b>OVEN CAPACITY:</b>
Install Clearance:	0" Side Cabinet 0" Back Wall 3" Top Cabinet Per Side	The cavity design of the oven provides the most precise temperature control, which delivers even heat distribution resulting in versatile performance. It has the largest oven capacity available on a 30" range and will accommodate a full-size commercial 18" x 26" baking sheet.

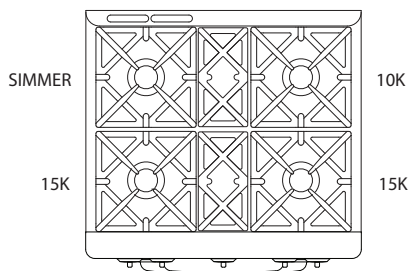

### INFRARED BROILER:

Because of its popularity in the commercial market, the direct-fired ceramic infrared broiler is standard on all residential ranges. The large burner produces 1850 F of intense, searing heat close to the burner, while effecting a gentler broiling for foods placed farther away. The broiler is fully recessed into the oven's top to create maximum cooking space.

### FULL MOTION GRATES:

Bring sauce to a boil while stirring on a front burner, then slide it to the rear to simmer while you saute up front! Our full motion grates allow you to easily reposition pots and pans from front to rear burners without lifting. The grates are also oversized to accommodate the largest stock pots and saute pans.



# RANGE HOOD FEATURES AND SPECIFICATIONS

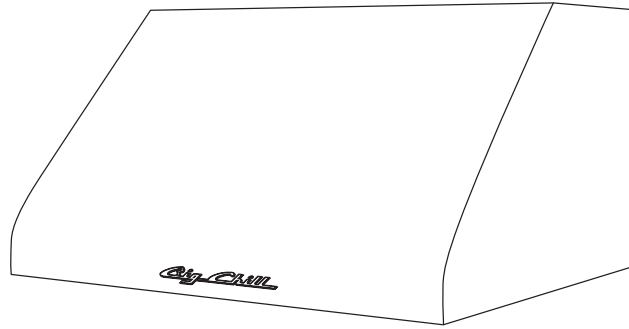

FRONT VIEW

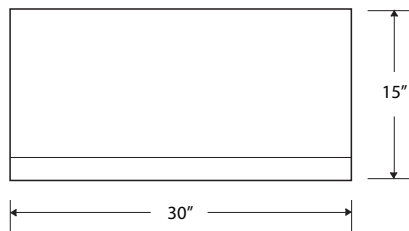

SIDE VIEW

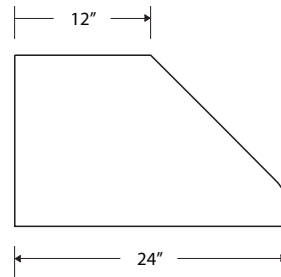

TOP VIEW

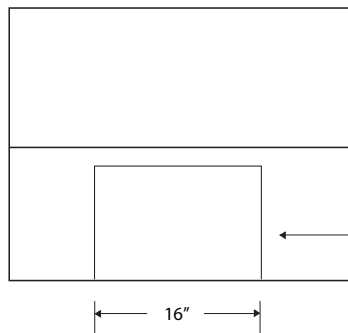

BACK VIEW

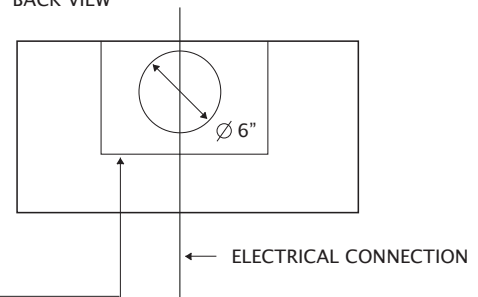

CUT OUT TO FIT L-BRACKET WITH BLOWER

ELECTRICAL CONNECTION

**ELECTRICAL REQUIREMENTS:**

- \*120 VAC, 15 Amps
- \*Light bulbs are PAR 16 60 watt halogen
- \*Blowers must be purchased separately

**STANDARD FEATURES:**

- \*Commercial grade 18 gauge 300 stainless steel construction
- \*600 CFM blower
- \*Welded seamless corners
- \*Dishwasher safe stainless steel baffle filters
- \*Variable blower control
- \*Halogen lamps with dimmer control
- \*Reversible top or rear exhaust
- \*Largest filtered capture in the industry

