

RANGE HOOD FEATURES AND SPECIFICATIONS

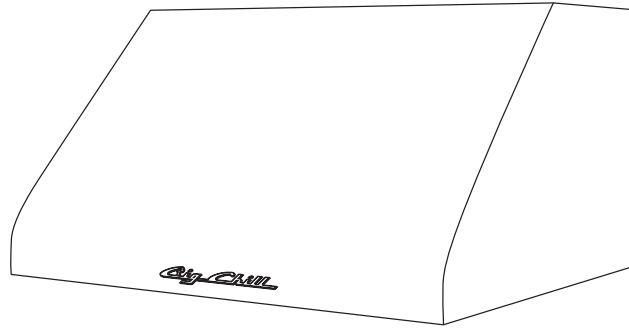

FRONT VIEW

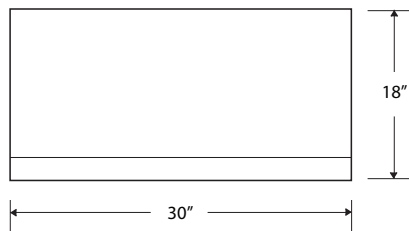

SIDE VIEW

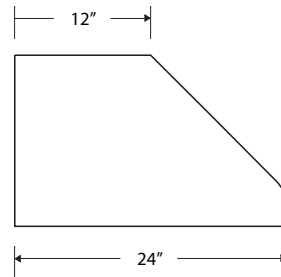

TOP VIEW

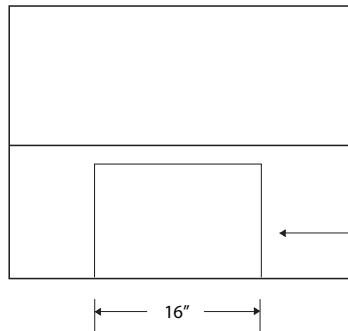

BACK VIEW

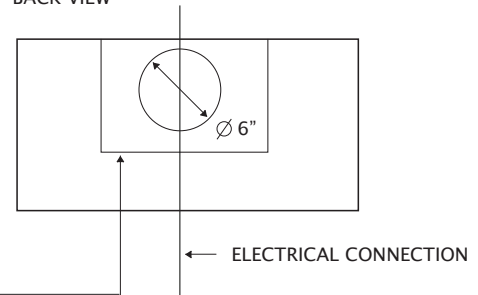

CUT OUT TO FIT L-BRACKET WITH BLOWER

ELECTRICAL CONNECTION

ELECTRICAL REQUIREMENTS:

- *120 VAC, 15 Amps
- *Light bulbs are PAR 16 60 watt halogen
- *Blowers must be purchased separately

STANDARD FEATURES:

- *Commercial grade 18 gauge 300 stainless steel construction
- *600 CFM blower
- *Welded seamless corners
- *Dishwasher safe stainless steel baffle filters
- *Variable blower control
- *Halogen lamps with dimmer control
- *Reversible top or rear exhaust
- *Largest filtered capture in the industry

